



DOSSIER & TECHNICAL RIDER (EN)

60% BANANA

A CHEERFUL MESSAGE FOR THE ANGRY CITIZEN

CONTACT

info@monkibusiness.nl – Benjamin Kuitenbrouwer
W www.monkibusiness.nl **F** circusmonki **I** monki_business

IN SHORT

DURATION : ± 30 minutes (maximum 3x per day)
LANGUAGE : Nederlands, Frans of Engels
AGE : 12+
FLOOR & SPACE : ± 8 x 8m • frontal setup audience • height at least 6m
RIGGING : anchor points needed
WE COME WITH : 1 artist • 1 technician



© HANNEKE MEIJERS

CREDITS

CREATION & PERFORMANCE

– Benjamin Kuitenbrouwer

CREATION & DIRECTION

– Bas van Rijnsoever

TECHNIQUE

– Arnold Schut of Cahit Metin of Bas van Rijnsoever

PRODUCER

– MONKI – TENT huis voor hedendaags circus

COPRODUCERS

– Cirklabo – De Grote Post – Over 't IJ

SUPPORTED BY

– Fonds Podiumkunsten – Amsterdams Fonds voor de Kunst – Werkplaats Diepenheim

RESIDENCIES

– Over 't IJ – Cirklabo – De Grote Post
Werkplaats Diepenheim

ABOUT 60% BANANA

In 60% Banana, Benjamin Monki Kuitenbrouwer gives you an optimistic view of humanity in a brand-new format: a circus lecture. He uses his acrobatic skills to tell the audience about the hopeful developments in the world. Swinging and climbing between the poles, and using data on extreme poverty, war victims and - among other things - population growth, he forms metres-high coloured graphs with elastic bands to make his point. "Things can be bad and getting better." – Hans Rosling (Factfulness). Monki defends the position that we do not deny the wrongs in the world if we try our best to

see positive developments. He refuses, just like Rutger Bregman, to be called naïve because he proclaims an optimistic message. Rosling, with his book *Factfulness* and his organization *Gapminder*, championed a worldview based on facts. He defended that we often have an overly negative view of the state of the world and humanity and that this negative view prevents us from imagining further positive changes. By telling a hopeful story about the developments of the past decades, he wanted to give people the belief that we can still bring about major changes in the future.

■

“I was inspired for this work by the Swedish scientist Hans Rosling. His contagious and stubborn optimism I hope to continue into the character of Professor Monki in this lecture a la circus”

– Benjamin Kuitenbrouwer –

■

MONKI (BENJAMIN) • BAS

BENJAMIN [MONKI] KUITENBROUWER (1988, Amsterdam) owes his nickname Monki to his loves for swinging back and forth between meters high poles as an acrobat. He calls himself a circus artist and stage artist. He makes performances in which he uses circus as a mediator between the things that concern him every day. In 2014 he graduated as a circus maker at the art school Codarts, specializing in double Chinese pole. During his education, he did an internship at dance company Dance Works Rotterdam André Gingras and worked with various groups. In 2017 his first solo performance *Not Somewhere Else* premiered and together with others he founded the collective *Sous le Manteau* and released the performance *Monstro*. That year also saw the release of the second solo performance *Static*, part of the *CircusNext* selection. With *TENT*, Monki made the performance *3* in 2015 and between 2019-2021 they together made the performances *Being Benjamin* (2020) and Monki's directorial debut *Jack* (2020), under the 'Nieuwe Makersregeling' of the Performing Arts Fund NL. Monki is a house maker at *TENT* from 2021-2024.

BAS VAN RIJNSOEVER has been working with Monki as house dramaturge since 2019. In 2008 he graduated from the Amsterdam School of the Arts as an actor specialized in mime. He works as an actor and maker for various international companies and collectives. He is also co-founder of *Stichting Nieuwe Helden*. His understanding of Monki's work, background as a conceptual maker and experience with socially engaged projects make him a perfect final director for this project. *60% Banana ins* has been a common creation between Benjamin and Bas.



© HANNEKE MEIJERS

GENERAL INFORMATION

PRODUCTION – Veerle van Lieshout – +31(0)623062985 – veerle@monkibusiness.nl
RIGGING – Benjamin Kuitenbrouwer – +31(0)652631675 – monki@monkibusiness.nl
TECHNIQUE – Arnold Schut • +31 6 51795376 • info@schuttechniek.nl

— WE ARE A TEAM —

VOORSTELLING 60% BANAAN – 60% SHOW 60% BANANA

Is a show that can perform on multiple kinds of locations, both inside in a theatre as outside on a festival or tent. The audience setup is frontal. For inside, an audience seating with height difference for the different rows of audience is required. The performance lasts about 30 minutes. It's possible to perform multiple times a day, with a maximum of 3 performances per day. There needs to be a minimum of 1,5 hours between the end of one show and the start of the next. Normally the first show cannot be before 14:00, mainly because of technical reasons regarding build up time.

DEMANDS PERFORMANCE AREA & RIGGING

The minimum floor surface of the performance area is 8x8 meters. The floor must be a dust free, dry surface. Minimum height under (eventual) grid of for example trees is 6 meters under the middle of the 'stage' area. Please contact us when this is not exactly the case, sometimes we can manage around a certain situation. For the setting up of the poles on the stage, anchor points are required. These have to be taken care of and paid by the organiser. See technical drawing for more information. We can assist with this. There is often more than one solution to realise these points, either with water tanks (IBCs) or blocks of concrete (minimum 750kg). Questions? Please contact Benjamin.

OUTSIDE, RAIN & SURROUNDING NOISE

In case of rain, there will be no performance. If it starts to rain during the performance, Benjamin decides himself during the performance whether he continues and how. This in relation to his safety. It's advised to take into account for the programme surrounding noise both from our show and from others. Benjamin's voice is amplified with a microphone, so we also make noise for other parties closely around

BUILD UP, BREAK DOWN, TRANSPORT & PARKING PERMIT

Time is needed for setting up and taking down the decor. The required time is dependent on the situation, but we calculate with a minimum of 4 hours build up time and 2 hours of build-down time. Including a half hour break after the last show. Build up time is including eventual setting and programming lights. In the last hour of the 'build up time', the floor is needed for warming up and sound checking. Then the light setup needs to be finished. In theatres, we ask one extra technician from the organisation. We come with 1 van and 1 car. In case of an outside performance, it's necessary that we can park the car close to the dressing room and/or stage. Any parking costs are for the organiser.

DRESSING ROOM & CATERING & SLEEPING & WASHING

A dressing room close to the performance area is necessary. There has to be a chair, mirror, coat rack and there is running water, preferably a (hot) shower as well. Catering is the responsibility of the organiser, except per diems have been discussed. Everybody eats vegetarian and there are no other specific diet wishes. When we perform several days on a location that we consider too far away to travel to-and-from from home, we ask the organiser to organise sleeping places, 2 separate rooms. If we perform multiple days in a row, the costumes need to be washed. In that case, we need a washing machine and eventually a dryer.

SOUND & LIGHT

For performing we make use of a PA installation from the theatre or festival with one stereo channel (computer, 3.5mm jack). We bring our own laptop. For performing outside, we use a sound installation from the organiser. This means a mixer with minimum 1 XLR input and a double jack (stereo) input. PA is dependant on the amount of audience. L / R speaker on feet is sufficient. 1 Shuko connection for a smoke machine on the performance area, front right. Transmitter for microphone, with belt pack and receiver. For the light, we use the light installation of the theatre. For outside, please contact us. Specific light drawings can be supplied.



MUSIC DURING THE SHOW

- 1 ARTIST: JACQUES TITLE: TOUT EST MAGNIFIQUE LENGTH: 5:05 (IN REPEAT DURING WALK-IN)
- 2 ARTIST: NILS FRAHM TITLE: SAYS LENGTH USED: 4:30
- 3 ARTIST: GOOSE TITLE: SYNRISE LENGTH USED: 7:10
- 4 ARTIST: DUNE TITLE: HAND IN HAND LENGTH: 4:35 (ON REPEAT DURING END)



SITUATION SKETCH

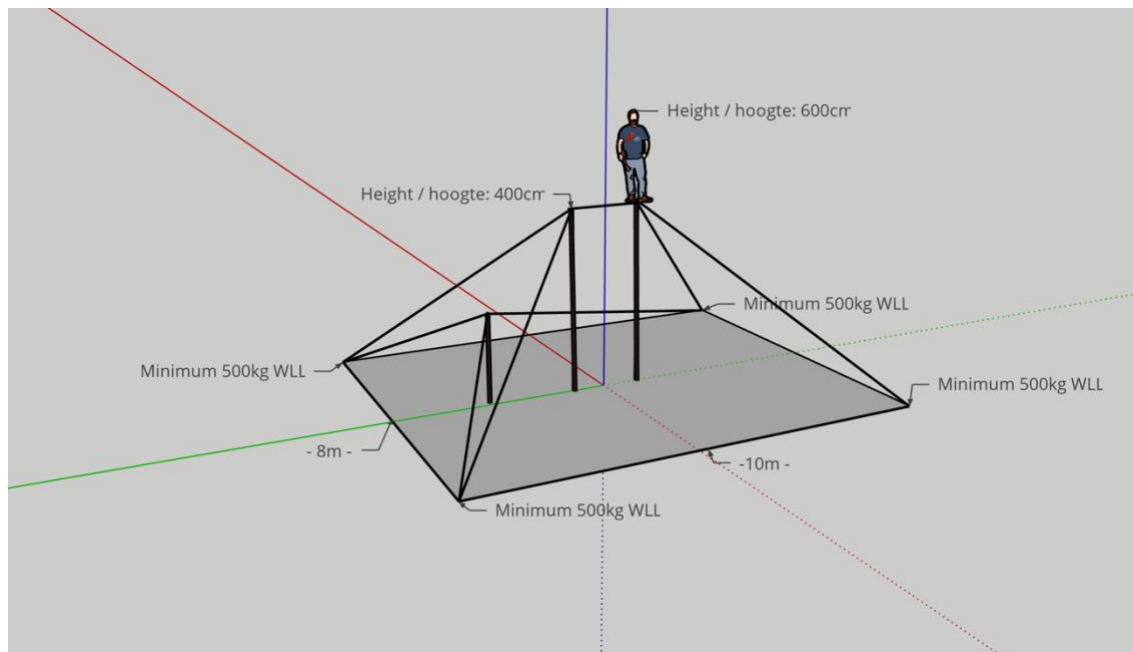



LIGHTPLAN

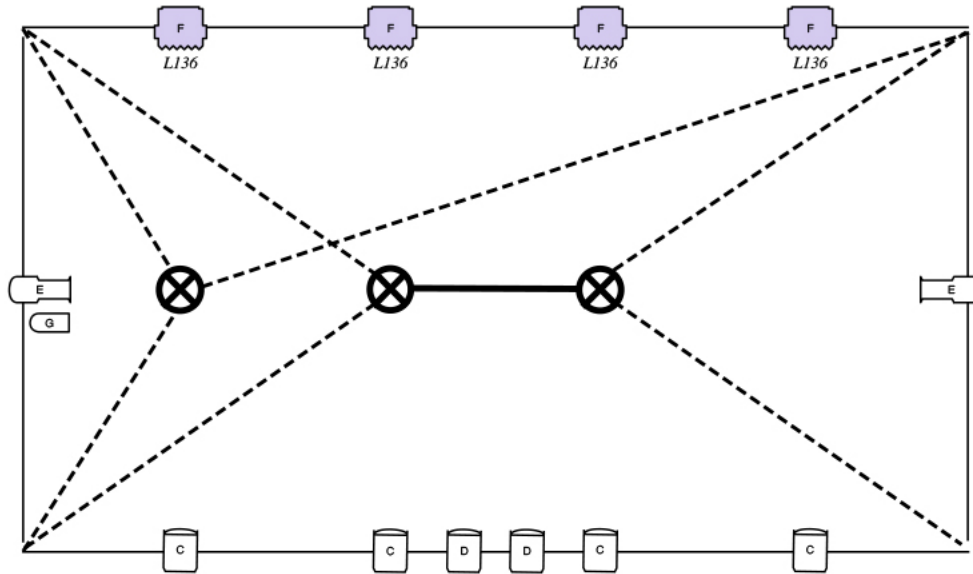

- A front total
- B special for volunteer on stairs
- C second plan front
- D special for on top of the pole's
- E Sides over the poles bottom to top
- F Back total
- G Floor light for elastics